

Schweizer 300 Scale

Body Kit

Instruction Manual



SPECIFICATIONS

- ✦ **YELLOW GELCOAT FIBERGLASS**
- ✦ **CRYSTAL CLEAR WINDSHIELD & WINDOWS**
- ✦ **OPENABLE PILOT DOORS**
- ✦ **REAR SCALE STRUTS**
- ✦ **SIMPLE QUICK RELEASE MOUNTING**

CENTURY HELICOPTER PRODUCTS
Designed and Developed in the USA
1st Edition November 1999

Building Instructions for the Schweizer 300 scale body kit

Introduction

Congratulations on your purchase of the Century Helicopter Product's Schweizer 300 scale helicopter body kit. This kit offers an easy entry into scale radio controlled helicopter flying whether you are just beginning into helicopters, getting into scale or an accomplished pilot. Though designed for the proven reliability of Century's Hawk helicopter mechanic Your new helicopter is sure to be an attention grabber at your local flying site.

Warning

This Schweizer 300 body must be assembled and installed strictly in accordance with these instructions. Failure to do so could cause failures in the body structure or the helicopter mechanics. Such failures could result in serious injuries. It is recommended that if you are in doubt of your abilities, you should seek the assistance from experienced radio control modelers and associations. As a manufacturer, we assume no liability for the use of this product.

Pre-assembly Information

Upon opening the Schweizer 300 body kit, you will find the major fiberglass and clear component parts and hardware bags. Hardware is identified by size of the fastener or part. This is done for ease of assembly. Be careful when opening the bags as not to lose any hardware, whenever possible keep all screws in a container until you use them up through the assembly process. Care has been taken in the filling and packing of each bag. However, mistakes do happen. If there is a shortage or missing hardware, please contact us at:

Century Helicopter Products
523 Sinclair Frontage Road
Milpitas, CA 95035
(408)942-9525

Schweizer 300 Construction Manual

This manual has been written to cover assembly of the Schweizer 300 Conversion kit CN1033 and is the supplemental instructions for the full kit CN1030 to work in conjunction with the Hawk III instruction manual. Through following the instructions, modifications can be made to the mounting for other helicopters in the 30-46 class. This instruction set is a supplement to the Hawk helicopter instruction manual, changes are listed below to the major areas that are different than the original kit.

Every attempt has been made to ease the assembly of your Schweizer 300. At each step where there is a complex assembly, detailed written instructions are provided to walk you through the building process. Take a few minutes before each step to review the instructions, examine the hardware utilized in that step, and compare the drawings & pictures to your work in progress.









Schweizer 300 Body Kit

Complete Steps 1 through 10

Schweizer 300 Hawk Conversion Kit

Complete Steps 11 - 17

Symbols used to help assist you in building the kit:

	Apply "Goop"		Repeat Steps as specified		Partially tighten		Helpful Tip
	Special Attention		Apply threadlock		Purchased Separately		Cut away Shaded Portion

Hardware Description and Identification:

M3x6 = 3x6mm and can refer to screws or fasteners.

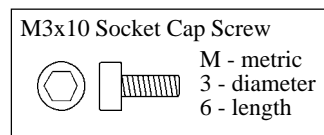
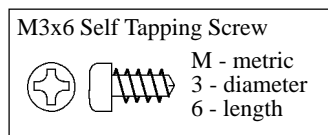

The tools and materials listed below are the minimum needed to build the Schweizer 300.

Screwdrivers - Slotted and Phillips head.
Hex Key 2.5mm
Long-Nosed Pliers.
Paper Clip
Scissors & Ruler
Loctite (thread lock liquid)
Clear cellophane or masking tape.
Drill and drill bits (1/16", 1/8")

Recommended Tools & Accessories

In addition, the following will make assembly and setup easier, and prove useful later in your model toolbox:

Primer and paint to match box art.
5.0mm Open End Wrench.
5.5mm Open End Wrench.
7mm Open End Wrench.

Step 1

Prepare the fiberglass, wash all parts in warm water with mild detergent to remove all residue used in the molding process and let the dry completely. The cabin set can be used as is with the bright yellow gelcoat, simply applying the decals directly on the fiberglass. Alternately the cabin can be painted to match an existing full scale Schweizer 300 or create your own unique paint scheme. When custom painting, read through the instructions and make all the necessary holes in the parts but do not attach any of the major components. Apply paint (remember to use a fuel proof paint) and complete all detailing before final assembly, some reopening of drilled holes may be necessary that may have filled in during the painting process.

Step 2

To attach the front windshield to the fiberglass cabin, carefully trim along the **outside** of the marked line. Note that the clear window is glued to the **inside** of the fiberglass canopy. Trim such that when the clear plastic bubble is inserted into the fiberglass cabin from the inside about 1/4" of the clear plastic material extends beyond the window boundary. When satisfied with the fit, glue the clear plastic to the fiberglass with "goop" adhesive. It is **not** necessary to glue the window frame strips to the clear plastic window. Apply the adhesive only to the perimeter of the fiberglass cabin. With final positioning of the windshield, take short lengths of clear tape and apply over the fiberglass strips on the outside of the cabin to hold the windshield in place while the adhesive dries. Make sure adhesive is thoroughly set before proceeding to any additional step utilizing the main cabin.

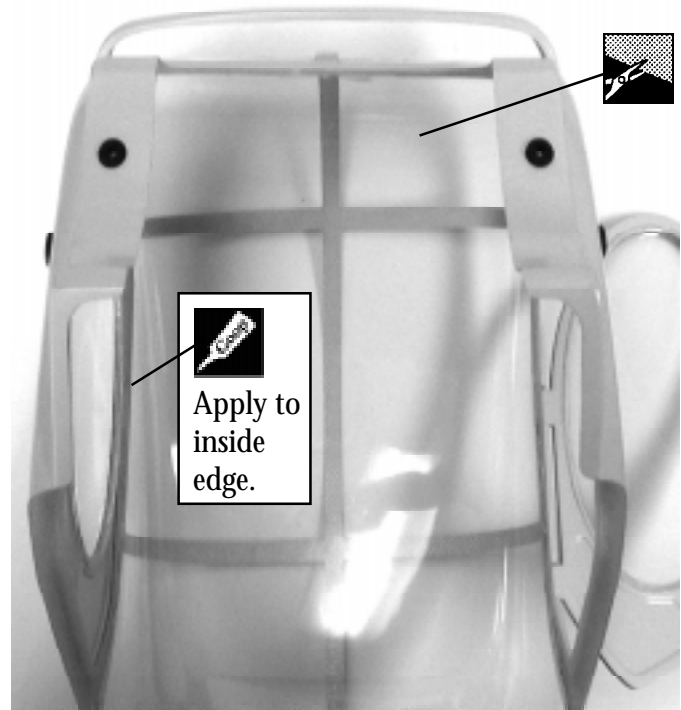

Tip: Use a small blade screw driver to apply the adhesive to the window/cabin joint. Attempting to apply the adhesive directly from the tube will likely result in runs on the exposed areas of the window.

Step 3

In a similar manner, trim excess material from **one** of the clear plastic cabin door windows. Again, the clear window material is to be glued to the **inside** of the door frame. For easy reference, position each door in the cabin and mark the inside surface with a pencil. Note that this trim process must be a little more exact in order to fit properly, the door window should only extend about 1/8" beyond the window opening. When satisfied with the fit, apply glue the door opening with "goop" adhesive. Make sure the adhesive is thoroughly set before proceeding to any additional step using the door. Repeat for the opposite door, Make sure you build a left hand and a right hand door.

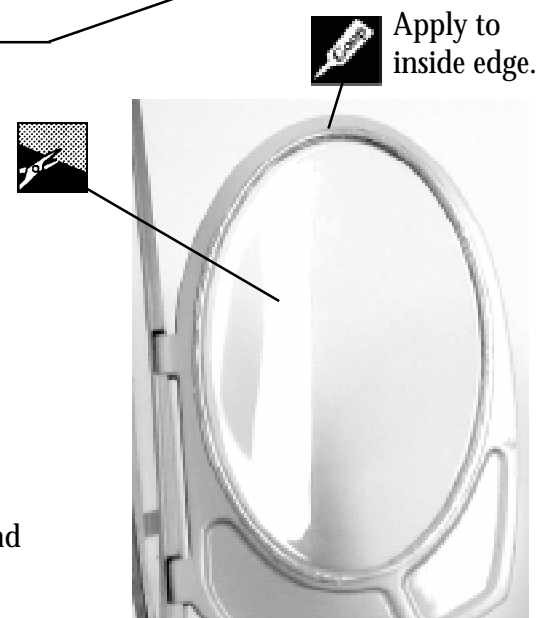

x2 Make one left and one right side.

Step 4

On the bottom of the canopy there are two small indentations. Drill two 3mm (1/8 inch) hole at these marks. Locate the Inside Canopy Mount [HI3129]. Note that this mount is designed to fit one direction, the wider end should face towards the helicopter. Attach the mount to the inside of the cabin utilizing two 3x10 self tapping washer head screws.



grommets
4 pcs

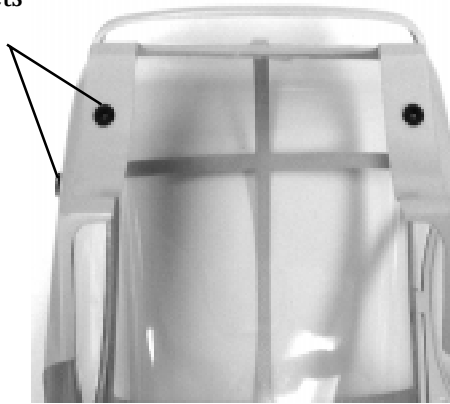

Step 5

The cabin has the four holes predrilled for the rubber mounting grommets. Install one grommet at a time and bond in place using “goop” on the inside of the cabin overlapping the outside edge of the grommet.

Step 6

Insert a spring loaded hinge pin into both the upper and lower hinge locations on one of the doors. Center the hinge pin within the door frame with the door closed. Make two marks on the outside of the cabin at each hinge with a pencil. Straighten out a paper clip bend the last 1/4” with pliers 90 degrees. Heat the bent end of the paper clip while holding with pliers and insert along the marks previously made. Insert into the solid section of the cabin hinge (the bent section) the hot metal will melt perfect size holes into the hinge pins. Before installing the door, add a small amount of “goop” to the paper clip and push into the hole, install the door into the cabin by compressing the hinge pins while sliding the door into new holes, allowing the spring loaded pins to “pop” into the holes you have made. Repeat this process for the other door.

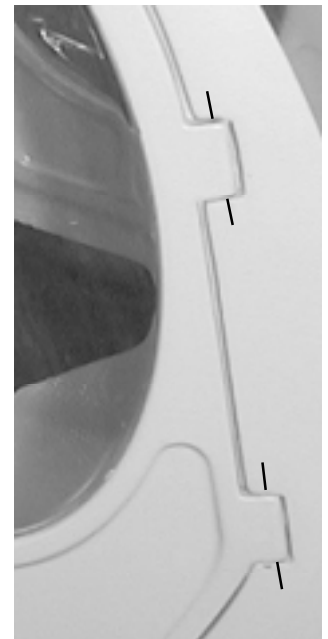

Step 7

Attach the main rotor guard to the top of the cabin with “goop” adhesive. Use two pieces of tape to hold in position while the adhesive dries. Allow to thoroughly set before proceeding.

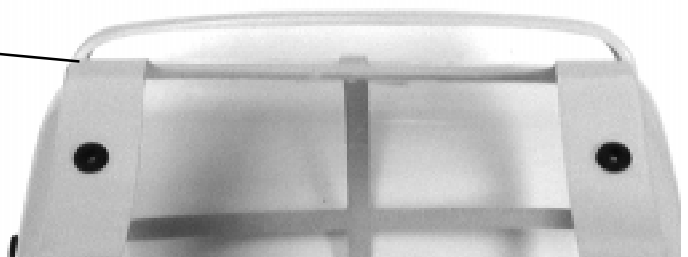

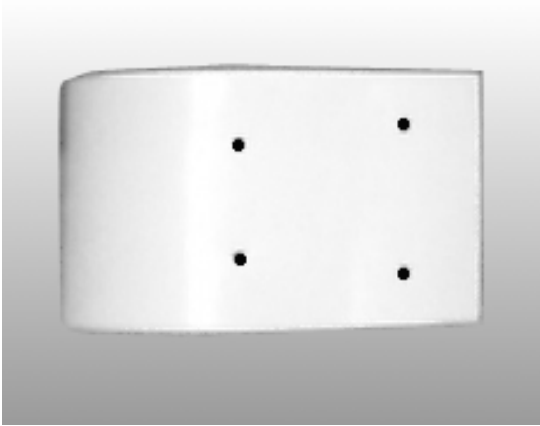

Step 8

Begin the gasoline tank assembly by locating the gasoline tank holding trays. Inspect the bottom of the tray and locate four hole location marks. Drill all four marks with a 3 mm (1/8") drill bit. Repeat this process on the second tray.

x2 Make two parts.

Step 9

x2 Make one left and right side.

Attach the mounting bracket to the gasoline tank tray with two 3x8mm socket cap screws and 3mm lock nuts. Position the bracket on the rear set of holes. Repeat this process on the second gasoline tank tray, making sure that you construct a left side tray and a right side tray. It is possible to attach the brackets and end up with two left (or right) hand sides.

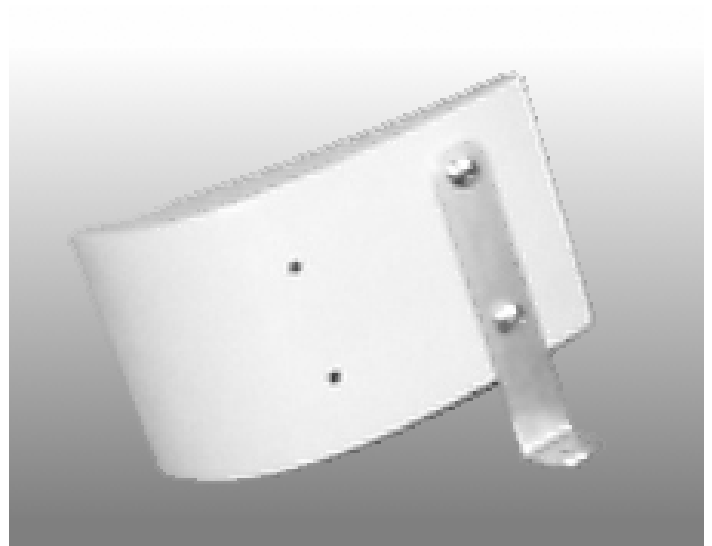

Step 10

Locate the two guide marks on the bottom of the fuel tanks. Drill two 1.5 mm (1/16") holes at the marked positions. Attach the gasoline tank to the tank tray using two 3x10mm self tapping screws. Apply a small amount of "goop" adhesive between the tank and tank tray before tightening down the screws. Make sure you orientate the tank correctly in the tank tray. Repeat this process for the second tank.

Tip If you lightly coat the self tapping screws with "goop" adhesive, you will be less likely to cause cracks in the gasoline tank fiberglass.



x2 Make one left and right side.

This completes the major assembly for the Schweizer 300 body kit, the next section covers installing the cabin set onto a Hawk helicopter kit. For those mounting on another helicopter brand, some modifications will be necessary to adapt to your helicopter. The following steps show the changes to the Hawk III instruction manual to mount the cabin set. It is recommended to have finished the helicopter assembly including servo and pushrods.

Step 11

In step 12, the short black ball has to be installed as shown, this is opposite to the instruction manual and is required for clearance on the elevator pushrod.

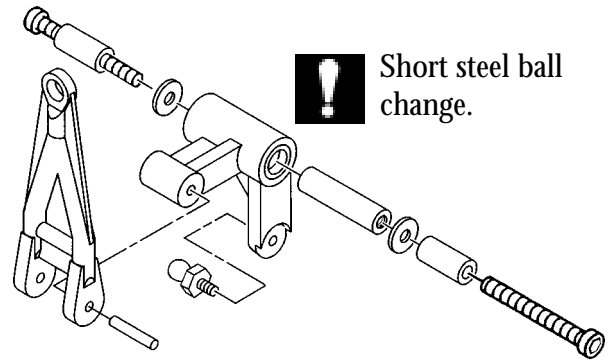

Step 12

In step 25, remove the two 3x16mm self tapping screws from the upper rear servo tray positions. Insert one 3x25mm threaded stud on each side, half way into these two holes. Apply threadlock to the remaining threads and tighten the Body Mount Posts against the servo frame. Please note, that the rudder and elevator servo are reversed, change the leads going to the receiver and the pushrods attached to the servos.



Step 12

While looking at the nose of the helicopter, attach the completed cabin set to the helicopter by starting from 45 degrees and align one side body mount post with the rubber grommet on the corresponding side and engage the bottom hook. Lift the rear remaining edge and flex the cabin gently to engage the second body mount post. Attach one fuel tank assembly by engaging the front tank molded pin into the mating grommet on the cabin rear. While looking from the side mark with a pencil through the hole in the bracket on the lower side frame. Remove the fuel tank and measure 21mm (1 1/16") horizontally across from the frontmost lower frame hole. At this intersection, drill one 1/16" hole approximately 1/2" deep into the plastic frames. Reinstall the fuel tank and insert one 3x8mm self tapping screw through the bracket to secure the tank. Repeat for the other side. To remove the cabin you do not need to remove the screws, simply separate the tanks and gently flex the cabin around one body mount post and rotate the cabin to remove.

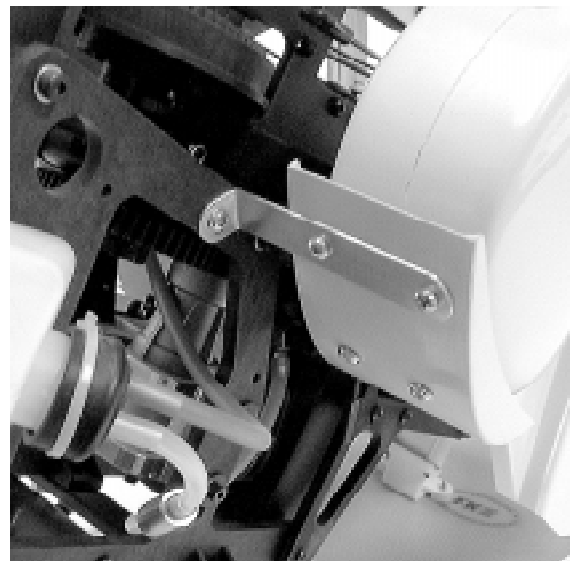

Step 13

The tail boom, tail pushrod guides and tail boom supports should be painted at this time before assembly. Remember that the pushrod guides may need to have the inside holes sanded slightly larger to fit the painted tail boom.

At Step 28, dis-assemble the tail pitch plate assembly by removing the lock ring carefully and reverse the pitch plate (part between the ball bearing and the tail pitch ball links). Reassemble the parts and epoxy or JB Weld the lock ring in place.

At Step 32, mount the bellcrank with the pitch plate assembly engaged. While assembling the tail rotor grips, examine the individual grips, one half has the recess molded for the 2mm nuts. This half of the grip has to be facing away from the gearbox when complete. Wait until the next step to attach the tail rotor blades.

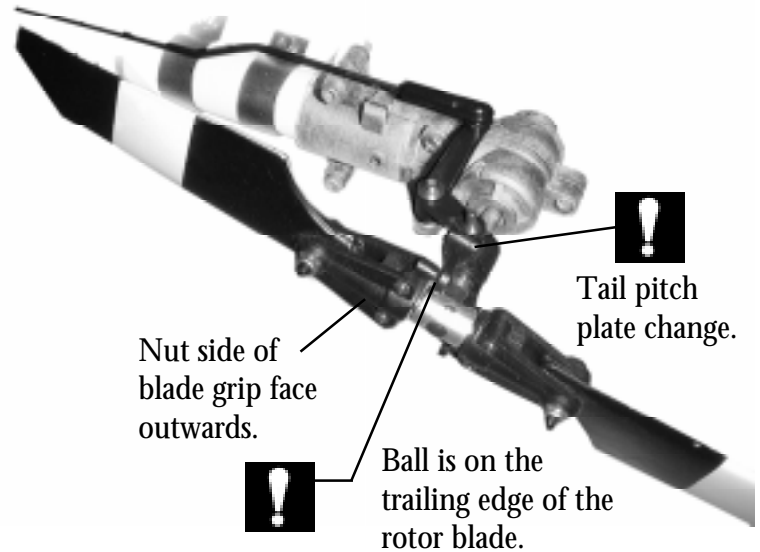

At Step 35, the tail pushrod guides have to be installed on the tail boom in the correct order with the strut and fin mounts. Starting from the tail gearbox, two fin mounts, one pushrod guide, two more fin mounts, one pushrod guide, one strut mount, one pushrod guide, and lastly one strut mount. Position the gearbox halves over the tail boom so the tail rotor assembly is on the left side of the helicopter (this is opposite to the Hawk instruction manual). In this position the tail pitch bellcrank will be on the top along with the pin from the pitch plate, tighten the gear box bolts and remove the original vertical and horizontal fin. Now while turning the main gear clockwise (the direction of rotation), attach the tail rotor blades with the leading edge on the same side of the ball on the tail blade grip as shown in the photo.

Step 14

Drill two 1/8" holes through each fin at the locations marked in the recesses. Using two 3x10mm Socket Cap Screws and 3mm locknuts attach the rear straight fin closest to the tail gearbox at a 45 degree angle. **Do not** overtighten these screws as you will damage the tail fins. Slide a tail pushrod guide in-between and mount the vertical tapered fin straight down at 2" in front of the first fin. Bend the 9" tail wire in a large radius as shown, remove the locknut on the lower mount (previously for the vertical fin) and attach one 3mm hex nut using threadlock, next thread the machined standoff on the bolt until the bolt is just visible through the vertical hole, slide the tail wire in place and secure using one 3x4mm set screw using threadlock. Position the wire to run vertically down while the curving backwards.



Step 15

At Step 37, locate the two sets of tail boom supports (one long set and one short set). Loosely attach one end of each of the short boom supports to the strut mount closest to the front using one 3x16 Socket Cap Screw with 3mm Locknut. Similarly, loosely attach the longest set of tail boom support rods the rear most strut mount using one 3x16 Socket Cap Screw with 3mm Locknut. Bring the two struts together, insert one 3x16mm Socket Cap Screw through the longer strut then the shorter strut and through the hole in the side frames and secure with one 3mm Locknut on the inside. Once both sets of struts are tightened on the lower side frames, align the struts and tighten the ends on the tail boom.



Step 16

The tail boom beacon can be detailed and is recommended to be bonded to the rearmost strut mount. When disassembling the tail for maintenance, or replacement it will come off with the struts.



Step 17

After attaching the rudder pushrod, follow the directions in Step 44 to setup the tail rotor control, remember that the rudder servo and pushrod are mounted on the right side of the helicopter. Adjust the positions of the tail pushrod guides to get the smoothest pushrod action, once this is finalized glue the guides in place with a few drop of Fast or Medium CA type glue. By using a few drops the guides can be easily removed if changing the tail boom becomes necessary.



Conclusion

This concludes the conversion for the Hawk III helicopter kit. For those customers adding the Schweizer 300 to a Falcon or Phoenix kit follow the same instructions with a change to Step 12 where the fuel tank mount to the frame, drilling the frame needs to be more accurate to keep the tapping screw secure in the aluminum. An alternate solution may be required.

Installation to other brands is simple requiring changes to the location on the helicopter mechanics to mount the cabin and the fuel tanks. Contact our technical support staff to provide assistance with other brands.

Decal Placement on Schweizer 300

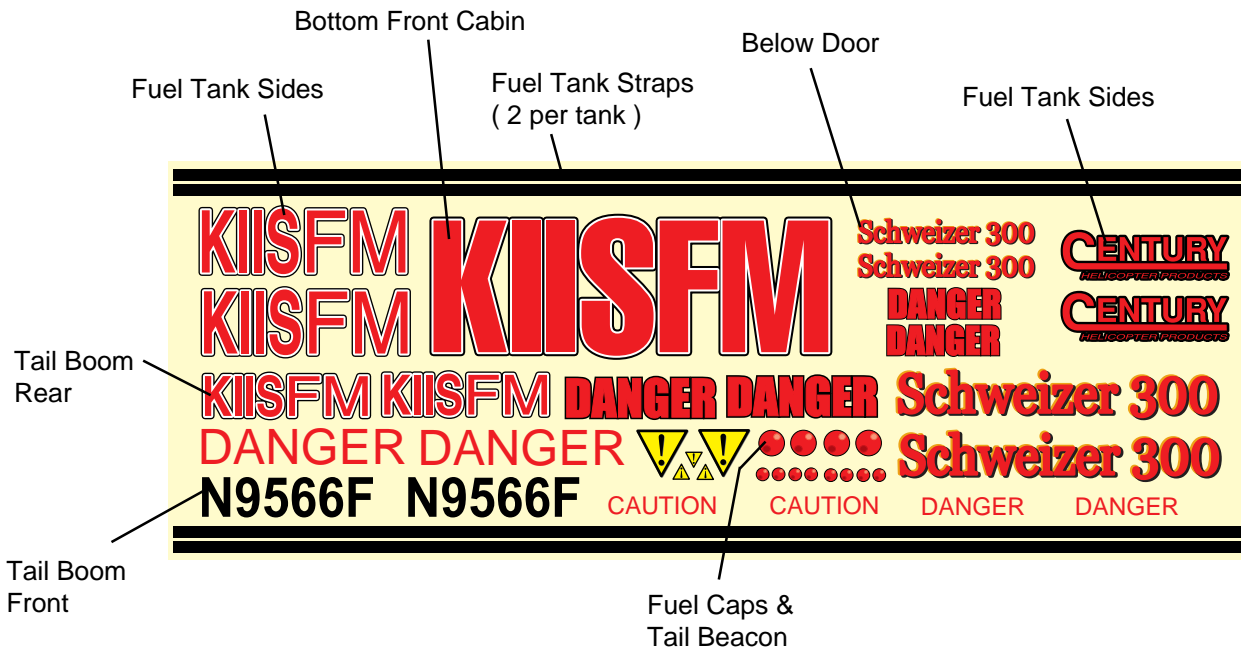

Scale Detailing

Detailing a scale model is a job that is never completed. The Schweizer 300 lends itself to a variety of scale “improvements” because of the simple nature of the full scale helicopter.

Detailing a scale model requires the desire to proceed, some skill, and a great deal of patience. It requires constant decisions of scale fidelity versus practicality versus flight stability. The most important tool you have in detailing a scale model is photographs of the full scale you are attempting to duplicate. The prototype Schweizer 300 used in the production of this kit was a traffic reporter helicopter for radio station KIIS - FM.

Some of the easy things you can do include coloring the main rotor blades, applying the decals in the proper locations and painting some of the components.

Coloring the Blades

The full scale has main rotor blades that are black in color. To achieve this effect, remove the white heat shrink covering from the provided rotor blades. Do this by carefully running an Xacto blade down the inside of the heat shrink, just as if you were opening an envelope with a knife. Cover the blades with black Monokote or Ultracoat - both work equally well. Check the blade balance when you're done, just to be sure; although the balance should not be changed by this recovering.

Painting

A text book can (and has) been written on painting models. Our prototype was painted with Chevron's Perfect Paint, but similar results can be expected from any of the popular hobby related paints. It is important to make sure any part to be painted has been thoroughly degreased and lightly sanded, including any metal parts.

The tail boom should be painted off the helicopter. First use primer on the boom with automotive spray can primer that is available in any discount automotive parts stores. We prefer the white primers because they seem to make the color coats more brilliant when done.

The tail boom, from the front up to the short tail boom supports, including those supports is white in color. From the short boom supports and all the way back to the tail rotor transmission is yellow in color, including the long boom supports. The yellow should match the color of the cabin gel coat. Both fins are red in color, as is the rotor blade guard on the top of the cabin. The red should match the red of the decals provided. The gasoline tank trays should be flat black in color.

The tail rotor blades are black with a white stripe about 3/4" wide right in the middle of the blade. Be careful of maintaining balance when adding paint to the tail rotor blades. A little goes a long way in this high RPM environment.

Final touches would include painting the navigation light beacon bright red, and the gasoline tank filler caps a bright silver with a red top cap. This can be done with plastic model paints. Decals are provided to simulate the gasoline tank hold down straps.

Added Realism

Study the photographs or a full scale example to see where you might be able to add a scale antenna, handle or lettering. Every little bit helps make your model more unique.

A feature that helps, if you are an experienced pilot, is to move the skids forward in the landing gear struts. This arrangement more closely resembles the full scale. Keep in mind that this scale "tweak" will make landings a little less stable.....one of those trade offs previously mentioned.

Conclusion

All of the above constitutes a step towards scale R/C helicopter flying. While you may not be ready to compete in the World Championships, you will likely have the most unique and admired helicopter at your flying field.

Schweizer 300 Bag Parts List

Rubber Grommets	4	M3x8 Socket Cap Screw	4
Magnets	2	M3x10 Socket Cap Screw	4
		M3x16 Socket Cap Screw	6
		M3x25 Threaded Stud	2
Body Mount Post	2	M3x8 Self Tap Screw	8
Fuel Tank Support	2	Hinge Pin	4
Tail Boom Bracket	6	M3x4 Set Screw	1
9" Wire	1	M3 Hex Nut	1
Wire Standoff	1	M3 Locknut	12

Optional Accessories to Complete your Schweizer 300

To truly make your Schweizer 300 scale, the high performance 3 blade scale rotor head is available. This rotor head consists of an all metal assembly, dual ball bearing aluminum main blade grips which feature the I.D.G. system (Individual grip damping) to dampen each blade individually to eliminate turbulence vibration which is crucial for super smooth flying with Century's multiple rotor blades. Century makes all the components required for this conversion: head assembly, 3 blade swashplate, custom follower and main rotor blades. Available for both 8 and 10mm main shafts.

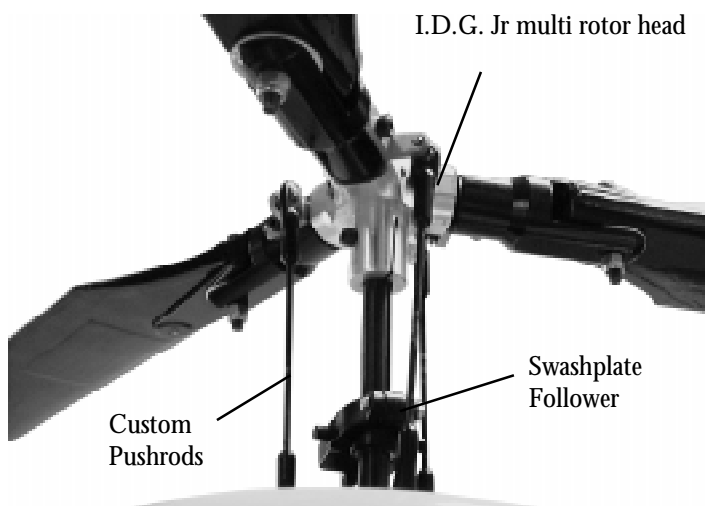
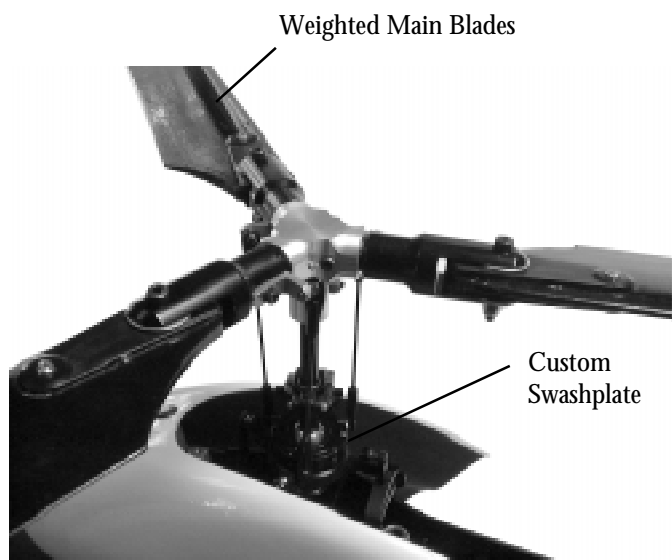

- CN1113 Multi 3 blade rotor head (30/46 size)
- CN1107-0 Multi swashplate conversion ring w/ball end
- CN1107-3 Swashplate - 3 blade (8 & 10mm shaft)
- CN1108 Swashplate Follower (8 & 10mm shaft) - Keeps swashplate timed to main blades
- CN2327A 3 Blade Multi Main Blade Set (550mm)

Schweizer 300 Replacement Part List

- CN1033-1 Front Fiberglass Cabin Only w/Fairing & Beacon
- CN1033-2 Windshield Only
- CN1033-3 Front Fiberglass Cabin & Front Windshield
- CN1033-4 Side Door w/ Side Window (1 side only)
- CN1033-5 Fuel Tank w/ Support Tray
- CN1033-6 Quad Tail Support Struts
- CN1033-7 Horizontal & Vertical Fins
- CN1033-8 Wire Tail Skid Assembly



CENTURY
HELICOPTER PRODUCTS

All rights reserved. No part of this publication may be reproduced, stored in a retrieval system or transmitted in any form or by any means, electronic, mechanical, photocopying, recording or otherwise, without the prior written permission of the publisher, Century Helicopter Products.